

Spring Return Roller Blind - Fitting & Operating Instructions

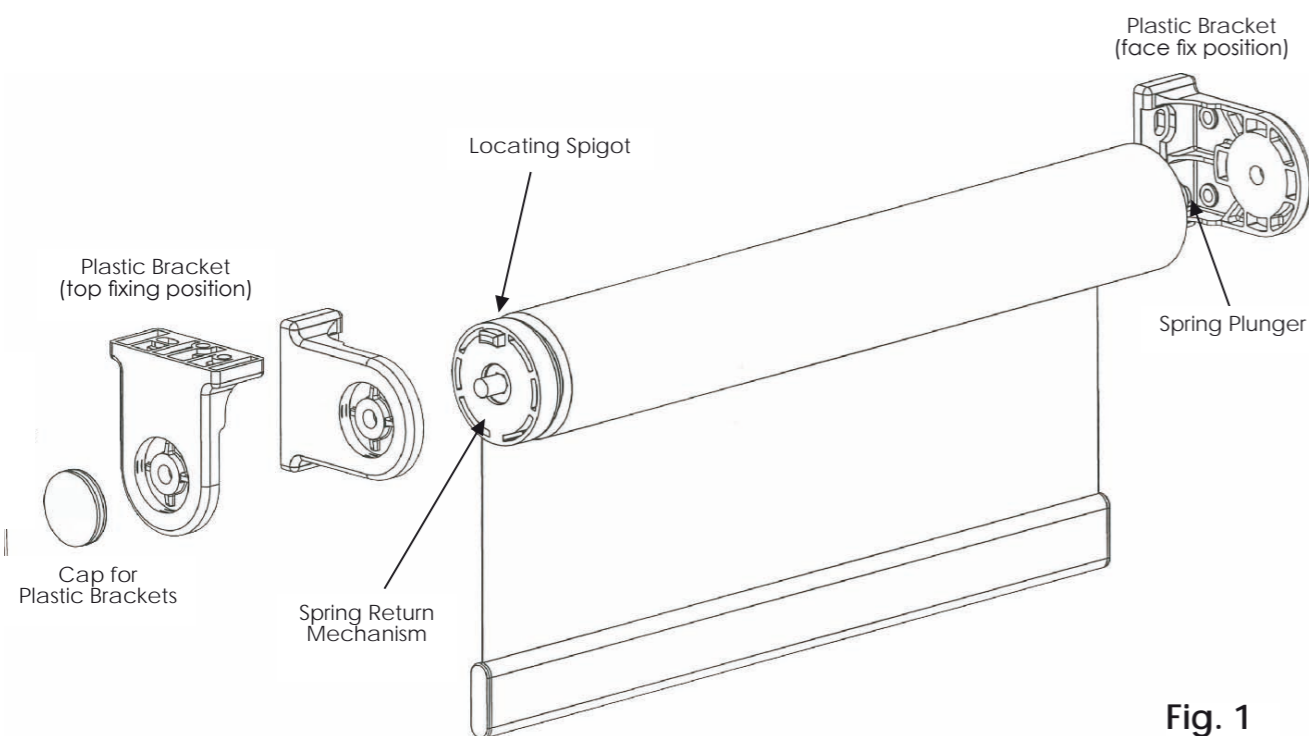

Fig. 1

Fitting the Brackets

Brackets can be top, side or face fixed to any flat surface. Check that the rolled up fabric will not touch any surface. To calculate the spacing between the brackets add 35mm (1 ³/₈") to the width of the blind fabric. Fix the brackets so that the outsides of the brackets are this distance apart.

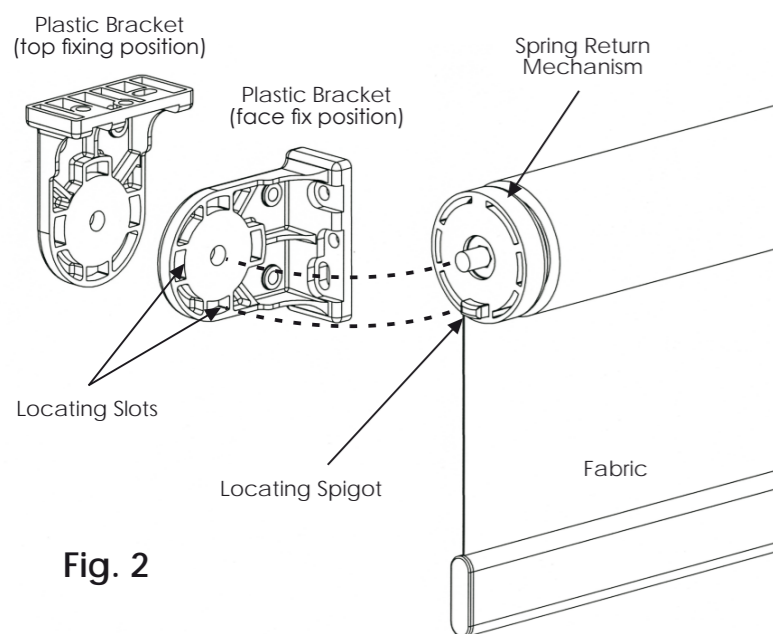

Fig. 2

Fitting the Blind

Make sure that the blind fabric is completely rolled onto the roller. Fit the spring plunger end into the right hand bracket. Push the blind to the right, depressing the spring plunger. Clip the blind into the left hand bracket*, making sure that the locating spigot is located on the lowest slot in the bracket - this is very important.

Tensioning the Spring

If the fabric does not wind up completely when the blind is operated, greater spring tension can be applied as follows:

- Pull the blind down 250mm (10") from its uppermost position and lock off.
- Remove the blind from the brackets and roll the material, by hand, back onto the roller
- Replace the blind into the brackets and check for correct tension.
- In the unlikely event that the tension is still insufficient, repeat steps a) to c).

Adjusting the level of the bottom of the Blind

If two blinds are fitted side by side and the bottoms cannot be positioned at the same level, the level of the bottom bar of either one of the blinds may be altered as follows:

- With the fabric completely wrapped around the roller, carefully remove the blind from the brackets.
- Take the spring return mechanism (see fig.2) and gently pull it 25mm (1") out of the tube, ensuring that the spring does not uncoil.
- Rotate the mechanism to the next position and replace it into the tube.
- Replace the blind into its brackets ensuring that the locating spigot is located in the lowest slot in the brackets. Adjust the level of the bottom of the blind.
- If necessary re-adjust the same blind, always rotating the mechanism in the same direction as before. This step can be carried out up to four times, giving a total of five steps in all.

Where there are more than two blinds together, adjust the level of the second blind to the level of the first blind, the level of the third blind to the second, the fourth to the third etc., until all of the blinds are aligned.

*Reverse Rolled Blinds

For reverse rolled blinds the spring should be on the right hand side.